

FIREBIRD



SOARING TO NEW HEIGHTS
IN OIL BOILER TECHNOLOGY



THE ULTIMATE HEATING EXPERIENCE

PART L
COMPLIANT
SEDBUK
BAND C



Slimline Heat Pac Range

THE ULTIMATE HEATING EXPERIENCE



-  Part L Compliant SedBUK Band C.
-  Designed for easy installation.
-  Reduced costs as building is not required.
-  Easy access to boiler and fittings for servicing.
-  Back Flue Outlet Option.
-  Fully Galvanised Housing. Full Stainless steel housing as optional extra.
-  Designed to comply with European Energy Efficiency Directive covered by OFTEC standards OFS A 100 (EN303 Part 4.)
-  Quality Assured manufacture to ISO 9002. Approved OFTEC Member
-  Riello or Ecoflam Max Burners
-  Frost stat factory fitted. (EX-Devon Only)
-  All Firebird oil boilers have a 2 year comprehensive warranty which extends to 5 years on the boiler shell.

DIMENSIONS & TECHNICAL INFORMATION

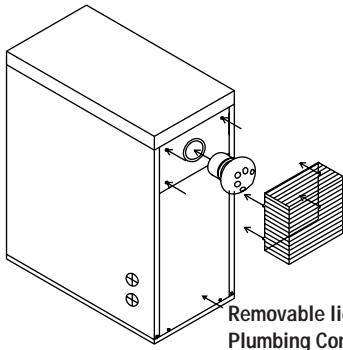
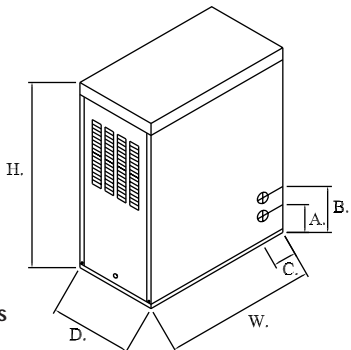
Removable lid to Access Plumbing Connections

SLIMLINE HEAT PAC	Outline Dimensions		
MODEL	D	W	H
50/70	410	760	925
70/90	410	760	925

Heat Pac	Plumbing Access Point Dimensions		
MODEL	A	B	C
50/70	140	230	115
70/90	140	230	115



For further information on all Firebird products please contact:

FIREBIRD BOILERS
Ballymakeera, Co. Cork.

Tel: [+353] 026 45253 Fax: [+353] 026 45309

FIREBIRD PRODUCTS

Shean, Forkhill, Newry. BT35 9SY.

Tel: [+44] 028 30888330 Fax: [+44] 028 30889096

FIREBIRD UK

Unit 6, Westover Industrial Estate,
Ivybridge, Devon PL 21 9 ES.

Tel: [+44] 01 752 691177 Fax: [+44] 01 752 691131

Int. Access Codes: Eg. N.I. +44 28 30888330



SLIMLINE HEAT PAC

Our **Slimline Heat Pac** is made from fully galvanised steel housing, suitable for all weather conditions. It comprises of the Popular Boiler, covering up to 90,000 Btu's in output, the burner already pre-set.

The **Slimline Heat Pac** is fully insulated with mineral wool insulation to prevent heat loss. There is sufficient space for fitting circulating pump if required.

The **Slimline Heat Pac** eliminates any building and so reduces cost and labour. It comes with removable back and front panels for access to any part of the unit. The piping may be carried out from the back or underneath.

Installation:
It is strongly advised, in the interest of performance and efficiency that each installation be properly commissioned using standard instruments and procedures, and that full maintenance service is carried out at least once per annum, by a fully qualified service engineer.

 **ALWAYS ENSURE FROST THERMOSTAT IS FITTED, WIRED AND OPERATING CORRECTLY** 

ALWAYS ENSURE WIRING IS CARRIED OUT TO E.T.C.I. STANDARDS.

© Copyright applies to all FIREBIRD products. Our policy is one of continual development and we therefore reserve the right to change without prior notice the specification of our products at any time and be without obligation to make similar changes in products previously produced.

E.&O.E.

Slimline Heat Pac Range