



Solar Controller Training Presentation





solar heated hot water

1. Solar Collector or 'panel'
2. Cylinder or 'store'.
3. Pump Station
4. Sealed System

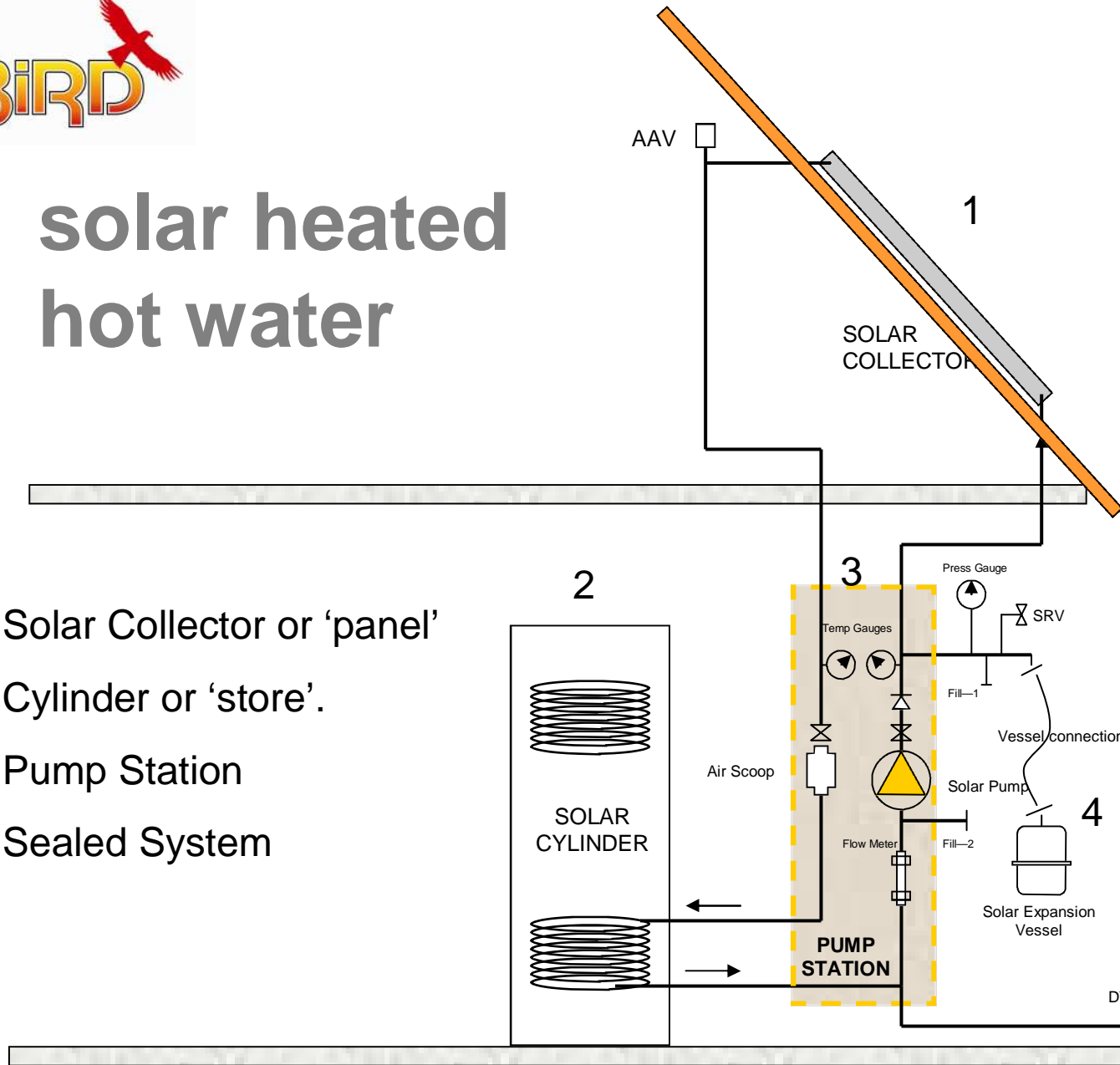

above roof connections

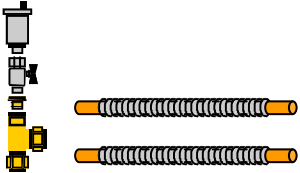
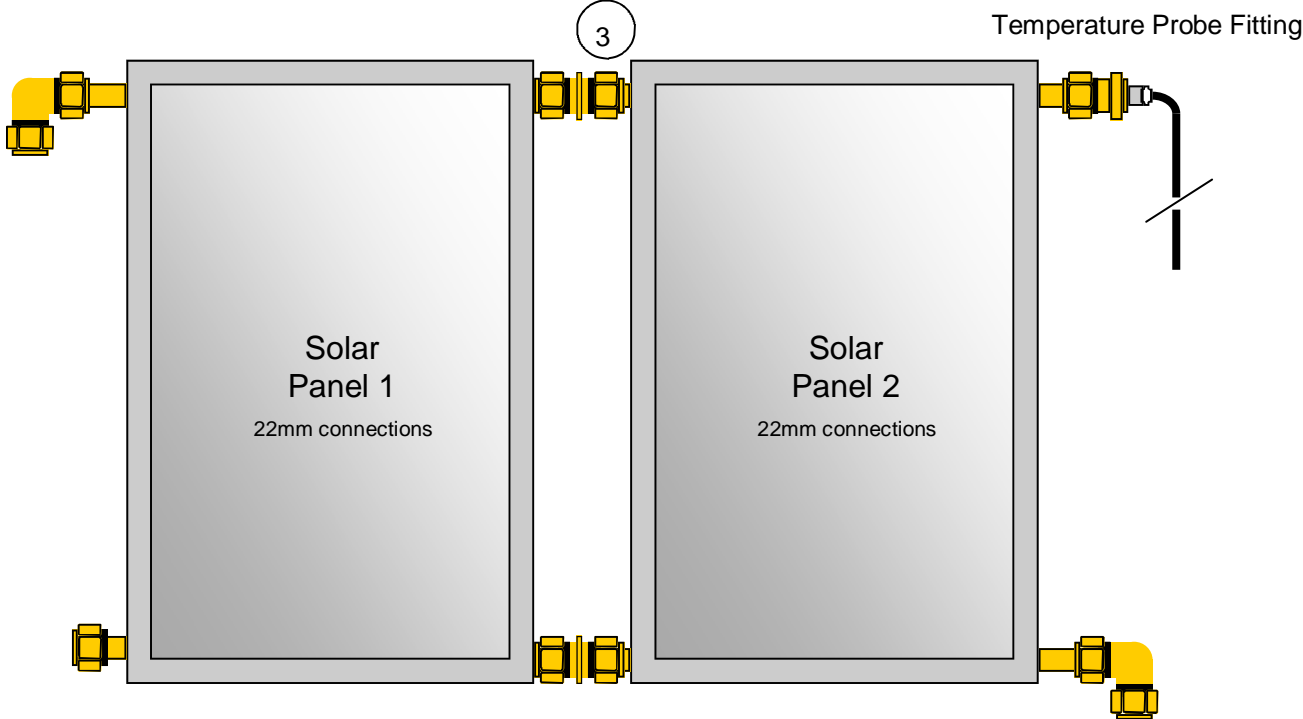

2

air vent above roof or in loft void?



The Solar Controller is a
'Temperature Differential Programmer'

It senses the temperature in key
positions in the system,

automatically switches on the pump (or
pumps) to transfer solar gain heat into a
store.

The controller maintains the safety of the
system with preset and adjustable limits,
and allows the installer to add additional
heat sources for back up when no solar
heat gains are available.



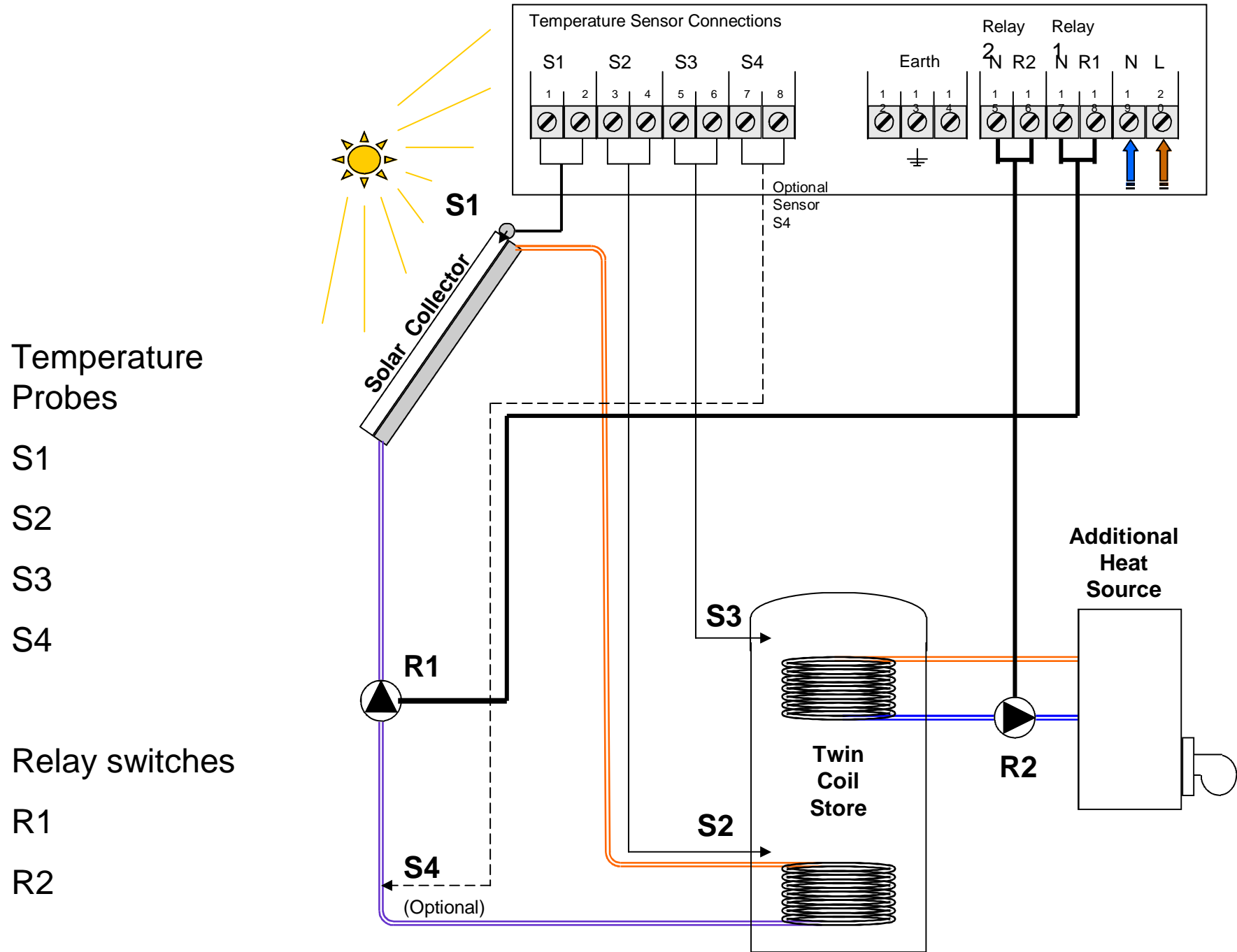



The controller is operated by 3 pushbuttons.

Button 1 scrolls forward through the options

Button 2 scrolls back

Button 3 is the SET command, for when you want to make a change to any of the factory set values.

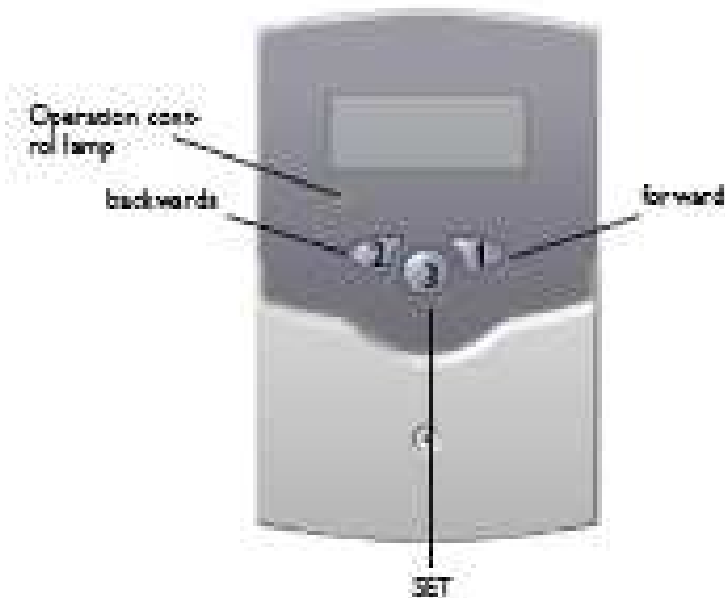



Slide down the plastic protection cover to reveal the controller.
 To access the electrical connection wiring terminals, remove the white lower plastic cover, one screw secures it to the body of the controller.

Power Supply connect on 19 (N) and 20 (L) - Earth on 12, and should be the last step of installation.
 Solar Pump is on R1 (18 L) and R2 (17 N) - on the pump station is pre-wired.

Terminals for making sensor and electrical connections are laid out like this.....

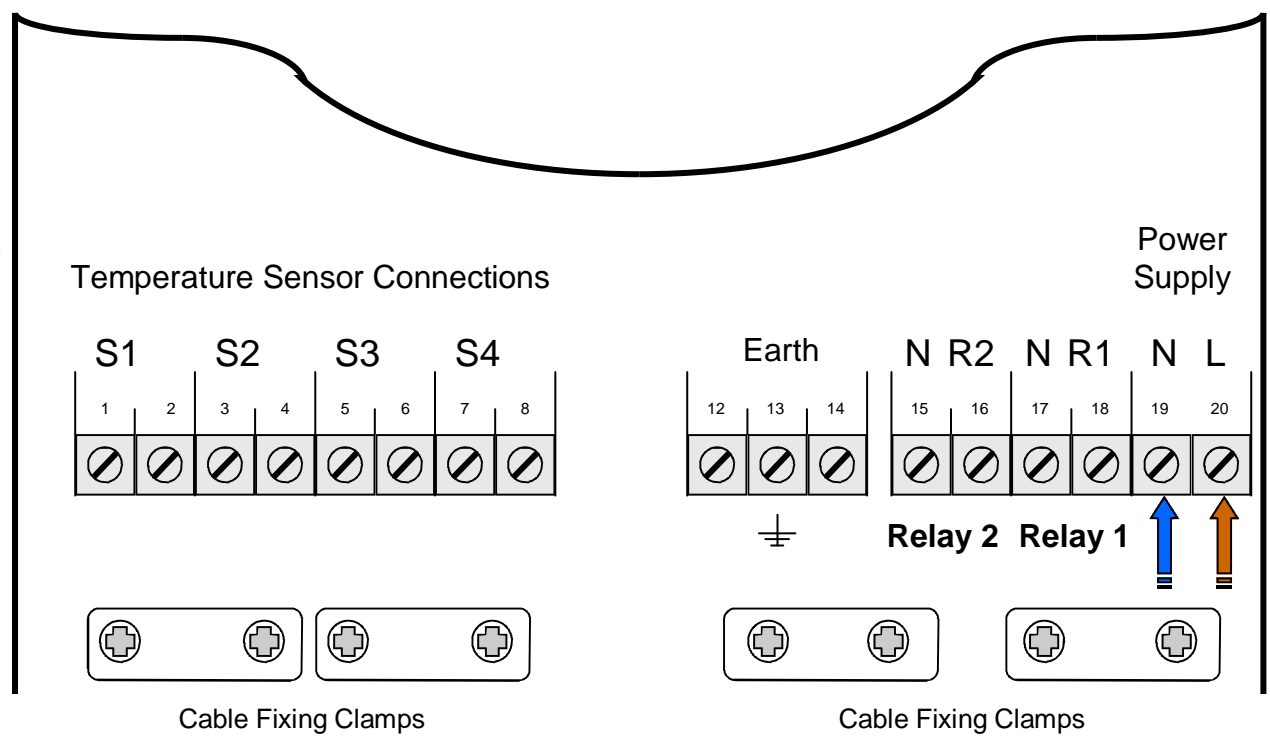



First Level Display / Functions

The first screen shows a diagram that indicates the controller is configured for the most basic system, i.e., what we call **Arrangement 1** (Arr 1)

Use the FORWARD button (on the right) to scroll through this first level of information.

When it reaches the h p SET screen, the user can go no further. Return to the first screen.

Note - If S3 or S4 sensors are not connected, or used, the appropriate screen will not appear.

Note - If a sensor is not connected properly, warning symbols will appear (see installation guide)

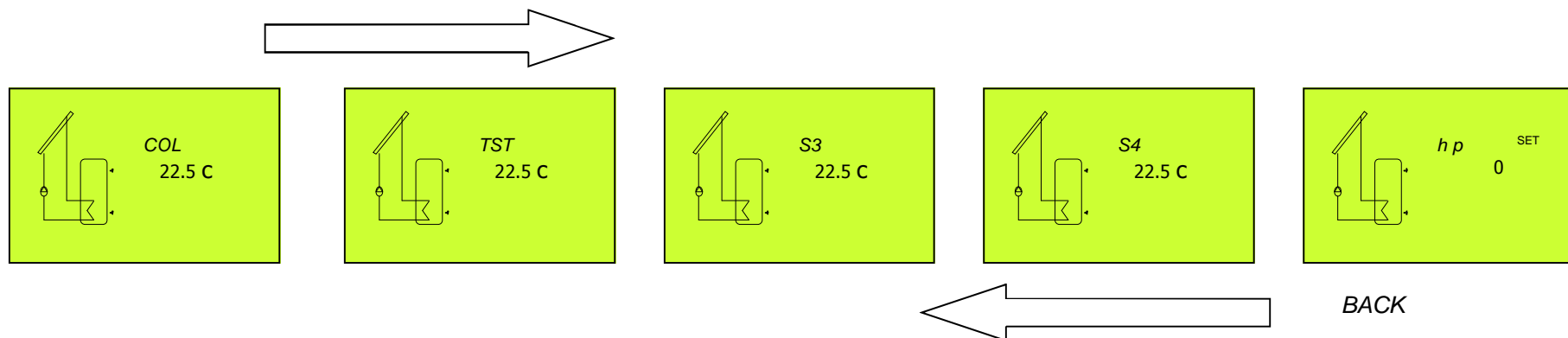



1. First Level Display

System information only, and designed that any tampering would have no ill effect on the system.

COL - The temperature at the collector. The probe is positioned at the hottest point on the panel.

TST - Temperature at the lower probe on the Cylinder Store
(when the system is programmed into Arrangement 2 mode, this becomes *TSTL*)

S3 - Temperature at the upper probe on the Cylinder Store.
(when the system is programmed into Arrangement 2 mode, this becomes *TSTU*)

S4 - Temperature Sensor 4, positioned on the return pipework. This sensor is used by the Solar Controller to calculate heat quantity measurement. When the HQTL setting is turned ON this becomes TRF

hp - Operating Time of the Pump or equipment connected to the relay.

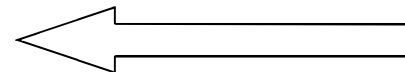
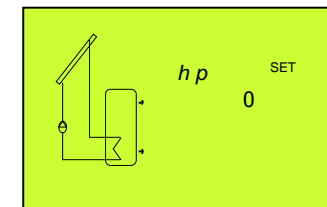
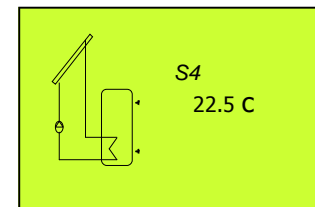
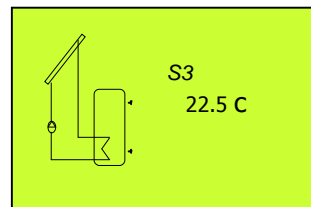
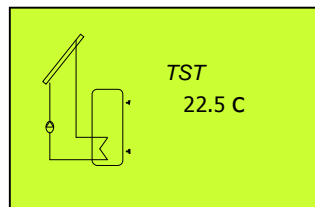
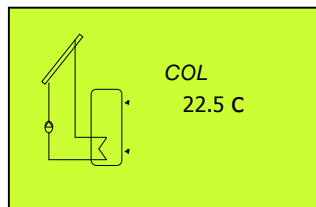
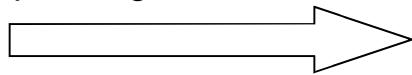

BACK

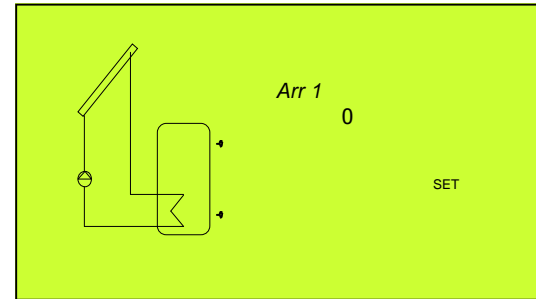
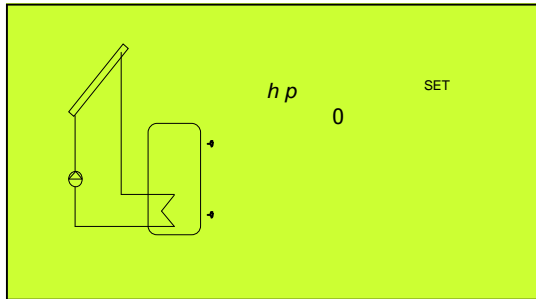

2. Accessing the Level 2 programming.

Use the FORWARD button (on the right) to scroll forward until it stops (on the *hp* screen)

NOW, hold the button down until the screen changes. As soon as you see the Arr 1 screen, release the button. You have now accessed the level of programming where the system factory settings can be adjusted.

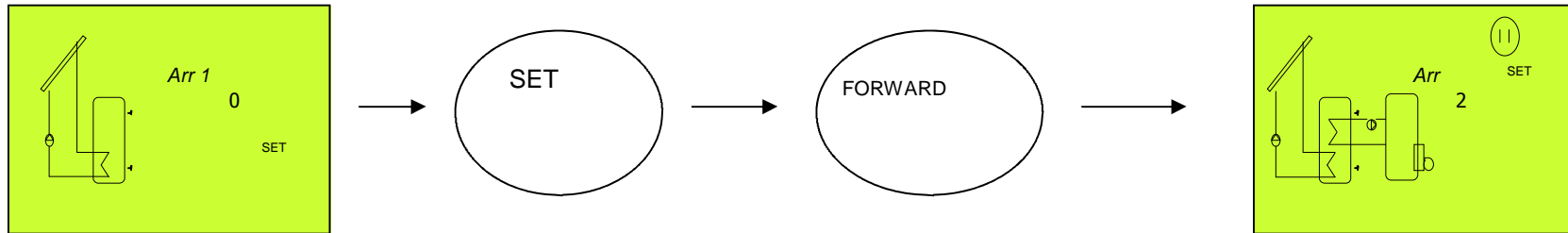

3. To programme the Controller to introduce the use of an additional heat source.

View the Arr 1 screen Press the SET button (the centre button of the three) *SET* 'flashes'.

Now press the *FORWARD* button (on the right).

The screen now shows the Arr 2 system. Press SET to confirm that this is the setting and system type that you require.



Changing basic factory settings

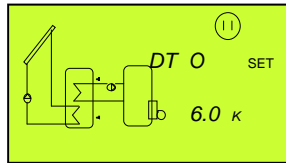

DT O

Switch ON temperature differential value. Factory set to 6.0C. Switches on the solar collecting system when the difference between the collector temperature and the store temperature reaches 6.0C

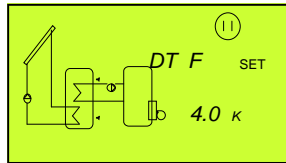

DT F

Switch OFF temperature differential value. Factory set to 4.0C. Switches OFF the solar collecting system when the difference between the collector temperature and the store temperature is 4.0C

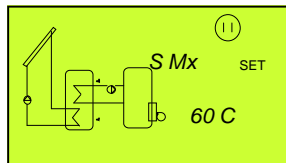

S Mx

MAXIMUM Store temperature (in the cylinder), factory set to 60.0C.
If anti-scald TMV's are used this could be raised to enable more of the Solar gain energy to be stored.
Note - uses Sensor 2 (lower S2)



protecting the system

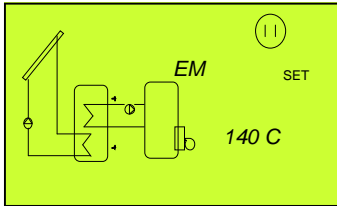

EM

EMERGENCY SHUT DOWN for where the **collector** temperature reaches 140C. The controller will shut down the pump to protect the system.

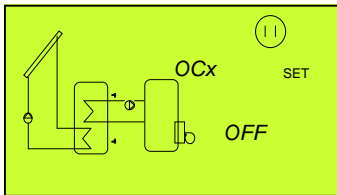

OCX

System Cooling option. Factory set at OFF. Could be used with the right system design to restart the solar pump to take heat out of the collector and over ride the max store temp (up to 95)

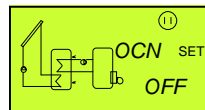

OCN

Not generally used in UK Solar systems. Factory setting OFF. Prevents the system operating at below the set temperature of 10 C. Example, hot climates where anti-freeze is not used in the system

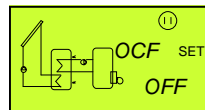

OCF

Not used in UK Solar systems. Factory setting OFF. Anti-freeze function.



protecting the system

another system cooling option

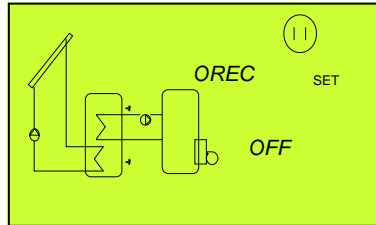

OREC

System Re-Cooling option. Factory set at OFF. Could be used with the right system design to restart the solar pump to take heat out of the collector and override the max store temp (up to 95) In this mode, it has the effect of allowing the pump to run as the collector temperature falls as well, for example in the evening. This then cools the store temperature down to the set maximum (S Mx)

optional temperature sampling for some types of tube collectors

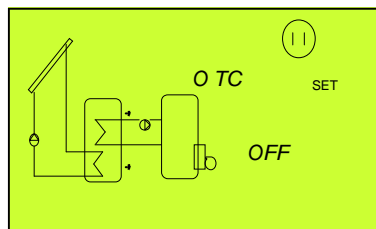

O TC

Tube Collector function. Factory setting OFF. Used in systems with evacuated tube collectors. Enables the pump for 30 seconds when a rise in temp of 2.0C is detected. This then moves water out of the tubes for a second temperature sampling, which may then find the temperature in the collector is actually higher than recorded at the sensor. The controller will then switch on the system even though the 6.0C DT O has not been reached.



additional heat source settings

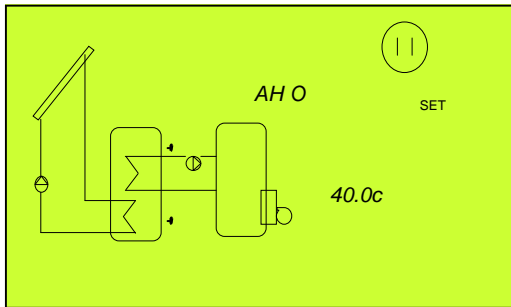

AH O **Switch ON** setting for **additional heat source**, i.e. a boiler.

Factory set at 40.0C, uses the temperature recorded in S3 (Sensor 3).

Also can be used for 'dumping' excess heat.

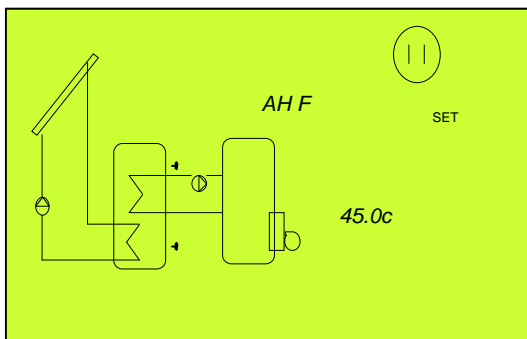

AH F **Switch OFF** setting for **additional heat source**, i.e. a boiler.

Factory set at 45.0C, uses the temperature recorded in S3 (Sensor 3).

Also can be used for 'dumping' excess heat.



Heat Quantity Measurement and Balancing

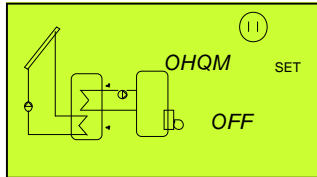

OHQM Heat Quantity Measurement function.
Factory set to OFF.

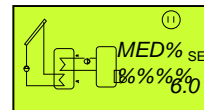
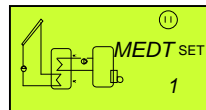
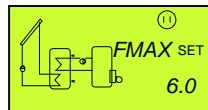

FMAX - allowance for regulated flow setting

MEDT - allowance for type of system fluid medium

MED% - allowance for % mix of system fluid medium



Over-rides for maintenance operations

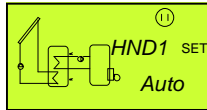

HND1

Manual over-ride on system for **RELAY 1** switching. Used for servicing or set up, allows the engineer to switch of the Auto mode, and select ON or OFF.

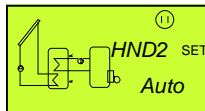

HND2

Manual over-ride on system for **RELAY 2** switching. Used for servicing or set up, allows the engineer to switch of the Auto mode, and select ON or OFF.



Factory settings

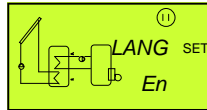

LANG

Language selection setting.
Press SET, then scroll back and forward to select df (German)
en (English) it (Italian) or fr (French) languages for the display screen.

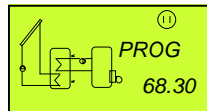

PROG

Factory information, no adjustment. Identifies the product design. In this case model 68.30

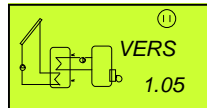

VERS

Factory information, no adjustment. Identifies the product version.



heat dumping

