

FIREBIRD



SOARING TO NEW HEIGHTS
IN OIL BOILER TECHNOLOGY















THE ULTIMATE HEATING EXPERIENCE

PART L
COMPLIANT
SEDBUK
BAND C

FIREBIRD S. Range - Kitchen Model

THE ULTIMATE HEATING EXPERIENCE



-  PART L COMPLIANT SEDBUK BAND C.
-  FLEXIBLE OUTPUT WHICH CAN BE ADJUSTED TO MATCH ACTUAL HEATING REQUIREMENTS WITHIN ITS OUTPUT RANGE.
-  FITS UNDER STANDARD KITCHEN WORKTOP ONLY 850mm HIGH.
-  FRONT ACCESS FOR EASY SERVICING & FULL VIEW.
-  CONVENTIONAL FLUE OR ROOM SEALED MULTI-DIRECTIONAL UP TO 310,000 Btu's. CONCENTRIC FLUE UP TO 200,000 Btu's. 200,000 Btu's - 310,000 Btu's TWIN PIPE BALANCED FLUE.
-  USE ONLY MATCHING FIREBIRD DESIGNED BALANCED FLUE KITS FOR LOW-LEVEL DISCHARGE.
-  FULLY INSULATED AND ACOUSTICALLY DESIGNED FOR ULTRA QUIET OPERATION.
-  DESIGNED TO COMPLY WITH EUROPEAN ENERGY EFFICIENCY DIRECTIVE COVERED BY OFTEC STANDARD OFS A 100 (EN303 PART 4).
-  QUALITY ASSURED MANUFACTURER TO ISO 9002. APPROVED OFTEC MEMBER.
-  RIELLO OR ECOFLAM MAX BURNERS.
-  EXTRA LARGE SIGHT GLASS FOR EASE OF CHECKING FULL FLAME.
-  MAINS-ON AND LOCK-OUT INDICATOR LIGHTS AS STANDARD.
-  ALL FIREBIRD OIL BOILERS HAVE A 2 YEAR COMPREHENSIVE WARRANTY WHICH EXTENDS TO 5 YEARS ON THE BOILER SHELL.

TECHNICAL SPECIFICATION 50-310 MODELS

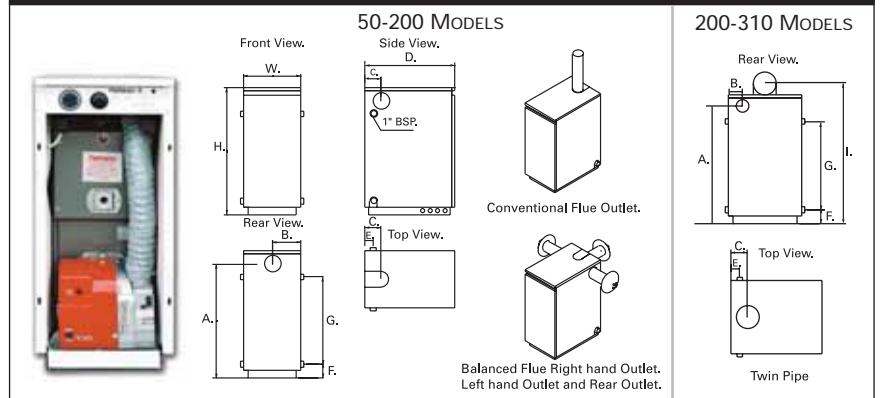

DIMENSIONS

70-90		90-120		120-150		150-200	
H.	845mm	B.	190mm	H.	840mm	B.	220mm
W.	380mm	C.	140mm	W.	440mm	C.	140mm
D.	595mm	E.	85mm	D.	595mm	E.	80mm
A.	745mm	F.	60mm	A.	745mm	F.	80mm
		G.	590mm			G.	580mm

200-250		250-310	
H.	960mm	C.	190mm
W.	510mm	E.	95mm
D.	820mm	F.	115mm
A.	885mm	G.	675mm
B.	90mm	I.	1115mm

TECHNICAL INFORMATION

OUTPUT RANGE	70-90	90-120	120-150	150-200	200-250	250-310
PRESSURE JET OIL BURNER	RIELLO - RDB SERIES (ECOFLAM MAX OPTION AVAILABLE)					
FLOW & RETURN CONNECTIONS	4x1" BSP	4x1" BSP	4x1 1/2" BSP	4x1 1/2" BSP	4x2" BSP	4x2" BSP
DRAIN OFF CONNECTION	1/2 BSP SOCKET & PLUG FITTED ON ALL MODELS					
FLUE OPTIONS						
A. CONVENTIONAL FLUE	4" -5"	4" -5"	5" -6"	6"	6" -7"	6" -7"
B. BALANCED FLUE	5" O.D.	5" O.D.	6" O.D.	6" O.D.	8" O.D.	8" O.D.
MAXIMUM OPERATING PRESSURE	3 BAR	3 BAR	3 BAR	3 BAR	3 BAR	3 BAR
TEST PRESSURE	4.5 BAR					
CONVENTIONAL FLUE DRAUGHT	MINIMUM: 0.04 INCHES WATER GAUGE. MAXIMUM 0.15 INCHES W.G.					
WEIGHT "in Kg"						
BOILER. BOILERHOUSE	82	95	131	150	170	230
BURNER	13	13	15	15	15	15
WHITE CASSED BOILER & BURNER	107	118	161	180	202	266
WATER CONTENT IN LITRES	19	24	28	37	53	65
TEMPERATURE CONTROL	CONTROL THERMOSTAT: ADJUSTABLE BETWEEN 65°C - 85°C. LIMIT THERMOSTAT: MANUAL RESET LIMIT THERMOSTAT FACTORY SET AT 110°C.					
ELECTRICAL SUPPLY	230v. AC 50Hz 5 AMP FUSE					
FUEL	28 SECOND KEROSENE (35 SECOND GAS OIL TO BE WITH CONVENTIONAL FLUE ONLY.)					

For further information on all Firebird products please contact:

FIREBIRD BOILERS

Ballymakeera, Co. Cork. Tel: [+353] 026 45253 Fax: [+353] 026 45309

FIREBIRD PRODUCTS

Shean, Forkhill, Newry. BT35 9SY. Tel: [+44] 028 30888330 Fax: [+44] 028 30889096

Int. Access Codes: Eg. N.I. +44 28 30888330



© Copyright applies to all FIREBIRD products. Our policy is one of continual development and we therefore reserve the right to change without prior notice the specification of our products at any time and be without obligation to make similar changes in products previously produced.