

FIREBIRD



SOARING TO NEW HEIGHTS
IN OIL BOILER TECHNOLOGY



PART L
COMPLIANT
SEDBUK
BAND C

THE ULTIMATE HEATING EXPERIENCE

Heat Pac Oil Boiler Range

THE ULTIMATE HEATING EXPERIENCE



-  Part L Compliant SedBUk Band C.
-  Designed for easy installation.
-  Reduced costs as building is not required.
-  Easy access to boiler and fittings for servicing.
-  Fully rotational STAINLESS STEEL FLUE.
-  Fully Galvanised Housing. Full Stainless steel housing as optional extra.
-  Also Available as a Combi or sealed system unit.
-  Designed to comply with European Energy Efficiency Directive covered by OFTEC standards OFS A 100 (EN303 Part 4.)
-  Quality Assured manufacture to ISO 9002. Approved OFTEC Member
-  Riello or Ecoflam Max Burners
-  Frost stat factory fitted. (EX-Devon Only)
-  All Firebird oil boilers have a 2 year comprehensive warranty which extends to 5 years on the boiler shell.



For further information on all Firebird products please contact:

FIREBIRD BOILERS

Ballymakeera, Co. Cork.

Tel: [+353] 026 45253 Fax: [+353] 026 45309

FIREBIRD PRODUCTS

Shean, Forkhill, Newry. BT35 9SY.

Tel: [+44] 028 30888330 Fax: [+44] 028 30889096

FIREBIRD UK

Unit 6, Westover Industrial Estate,

Ivybridge, Devon PL 21 9 ES.

Tel: [+44] 01 752 691177 Fax: [+44] 01 752 691131

Int. Access Codes: Eg. N.I. +44 28 30888330

DIMENSIONS & TECHNICAL INFORMATION



Sealed System Option Available Up to 150,000 Btu's

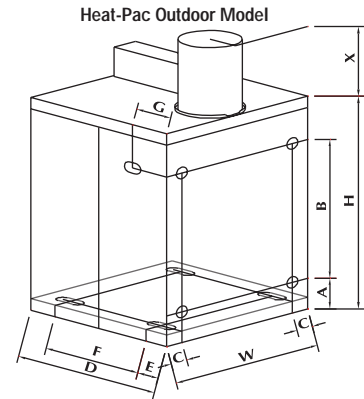

Heat Pac MODEL	Outline Dimensions			
	D	W	H	X
70/90	625	655	945	310
90/120	625	710	945	340
120/150	735	720	1010	340
150/200	860	895	1225	340
200/250	860	895	1025	350
250/310	960	950	1125	350

Heat Pac MODEL	Plumbing Access Point Dimensions					
	A	B	C	E	F	G
70/90	170	575	120	100	420	175
90/120	170	575	120	100	420	175
120/150	170	640	80	180	475	85
150/200	170	640	90	135	590	85
200/250	160	655	90	100	630	105
250/310	230	700	90	100	730	100

HEAT PAC

Our Heat Pac Range is made from fully galvanised steel housing, suitable for all weather conditions. It comprises of the Popular Range, covering up to 310,000 Btu's in output, the burner already pre-set, and the pre-wired limit stat.

The Heat Pac is fully insulated with mineral wool insulation to prevent heat loss. There is sufficient space for fitting circulating pump as required.

The Heat Pac eliminates any building and so reduces cost and labour. It comes with removable sides for easy access to any part of the unit. The piping may be carried out from the back or underneath.

Installation:

It is strongly advised, in the interest of performance and efficiency that each installation be properly commissioned using standard instruments and procedures, and that full maintenance service is carried out at least once per annum, by a fully qualified service engineer.

ALWAYS ENSURE FROST THERMOSTAT IS FITTED, WIRED AND OPERATING CORRECTLY
ALWAYS ENSURE WIRING IS CARRIED OUT TO E.T.C.I. STANDARDS.

© Copyright applies to all FIREBIRD products. Our policy is one of continual development and we therefore reserve the right to change without prior notice the specification of our products at any time and be without obligation to make similar changes in products previously produced.

E.&O.E.

Heat Pac Oil Boiler Range