



EXCELSTOR SOLAR

UNVENTED WATER HEATERS

Installation and Technical Manual



Important -This Manual Should Be Left With The Cylinder After Installation

Contents

Section		Page
1	Introduction	2
2	Technical specifications	3
3	Check list	3
4	General requirements	4
5	Primary circuit installation	7
6	Secondary circuit installation	7
7	Discharge arrangement	8
8	Electrical installation	11
9	Filling and commissioning	13
10	Servicing and maintenance	13
11	Anode Replacement	14
12	Fault finding	15
13	User instructions	16
14	Warranty	16
15	Part Numbers	17
16	Service Record	18

1. Introduction

The **EXCELSTOR SOLAR cylinder** is a high quality stainless steel unvented cylinder designed for use with all solar systems to provide hot water from a cold mains water supply of between 3bar and 12bar. Reduced performance is available at lower pressures but the units are not suitable for pressures lower than 1.5bar and flow rate of less than 20 litres per minute. The indirect heat exchange surfaces are designed to provide a rapid heat up time. The unit comes complete with all the necessary safety equipment to comply with legislation governing the installation of such systems.

1.1 Cylinder Suitability:

The **EXCELSTOR SOLAR cylinder** should only be used as part of a solar installation and configured as shown in figure 1.2. Additional safety devices may be required if the cylinder is operated with other heat sources.

2. Technical Specifications

Model number	175 si	215 si	255 si	305 si
Storage capacity (litres)	175	215	255	305
Cylinder diameter (mm)	574	574	574	574
Aux water volume (l)	105	140	180	230
Overall height (mm)	1300	1542	1809	2085
T & P valve (mm)	1080	1322	1589	1865
Lower immersion (mm)	593	593	593	593
Top immersion (mm)	-	-	-	-
Solar flow (mm)	542	542	542	542
Solar return (mm)	380	380	380	380
Cold inlet (mm)	300	300	300	300
Solar coil size (sq.m)	1.1	1.1	1.1	1.1
Aux. Coil size (sq.m)	0.75	0.75	0.75	0.75
Auxiliary flow (mm)	904	904	904	904
Auxiliary return (mm)	724	724	742	742
Weight when full (Kg)	223	271	318	378
Heat-up time (mins)*	18	21.5	25	30
Re-heat time (mins)*	13	16	19	22
Heat loss in 24hrs (kW)	1.78	2.19	1.31	2.51
Secondary return	•	•	•	•
Primary flow/return connections (mm)	22	22	22	22
Cold feed/hot draw off connections (mm)	22	22	22	22
Maximum water supply pressure (bar)	12	12	12	12
System operating pressure [pre-set] (bar)	3	3	3	3
Expansion vessel charge pressure (bar)	3	3	3	3
Maximum primary working pressure (bar)	3	3	3	3
Package includes:				
Expansion vessel (size in litres)	18	18	25	25
Inlet valve group	•	•	•	•
(pressure reducing valve, non-return valve,	•	•	•	•
T & P valve 7bar 90oC [factory fitted])	•	•	•	•
15-22mm tundish	•	•	•	•
22mm motorised valve	•	•	•	•
Control/limit thermostat box	•	•	•	•
Immersion heater	-	-	-	-

2.1 Heat-up & Reheat Times*

*Heat-up and reheat times are for a guide only and are based on a primary flow temperature of 60°C and heating water from 15°C to 60°C. The immersion of the cylinder must be used to raise the temperature to 60°C from the maximum temperature achieved at any time by the solar system,. Reheat times are those to heat 70% of the cylinder from cold.

2.2 Connection

2.2.1 SOLAR Indirect

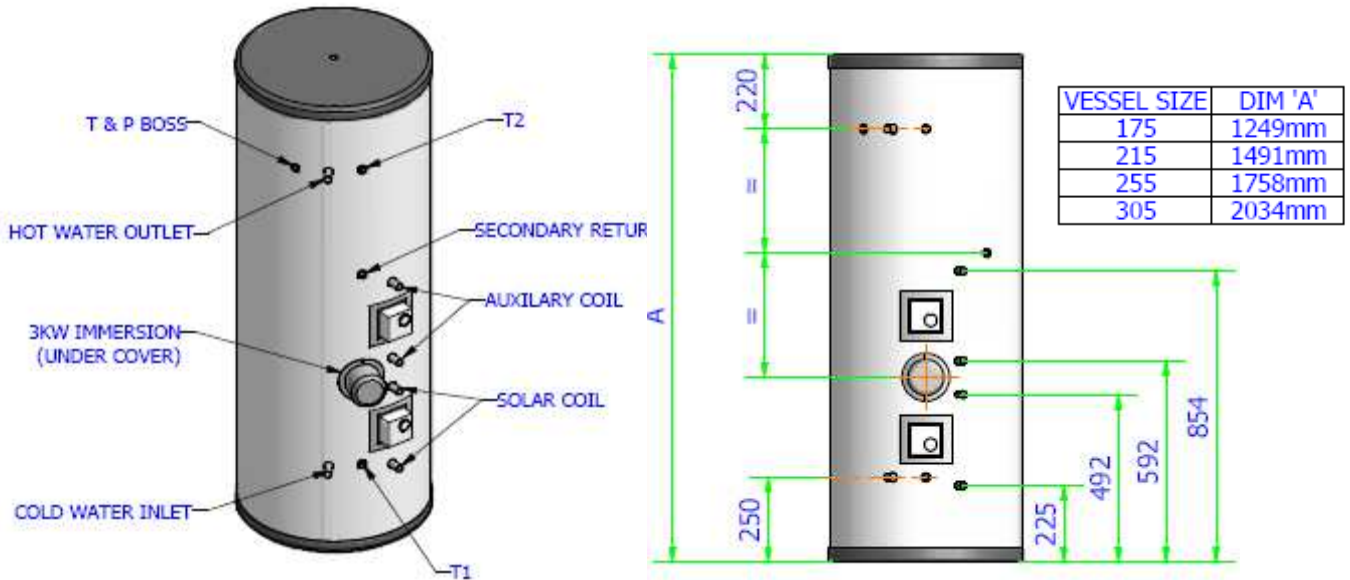

2.2.2 SOLAR Single Coil Direct Electric

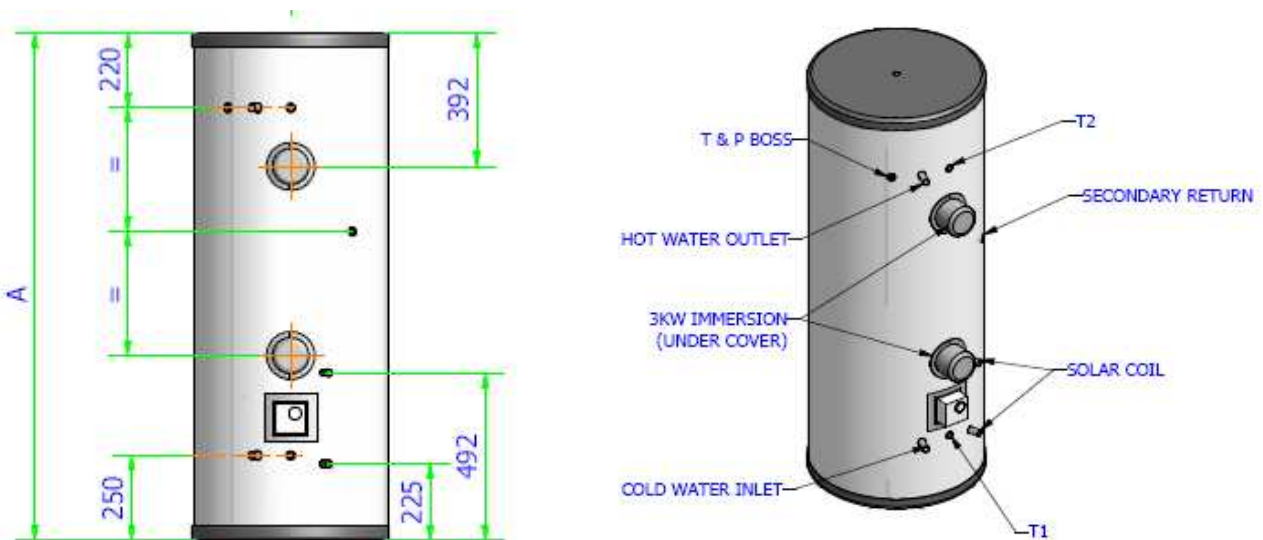

VESSEL SIZE	DIM 'A'
175	1249mm
215	1491mm
255	1758mm
305	2034mm

3. Check List

- Cylinder
- 25litre Expansion vessel
- Expansion vessel bracket
- 22mm Inlet group (Pressure reducing valve, Expansion relief valve, non-return valve, line strainer)
- ½" T/P valve, 7bar/90°C factory fitted
- 15/22mm Tundish
- 2 x Twin Thermostat + Cut-out
- Immersion heater
- 1x 22mm two-port Motorised Valve (Indirect cylinders only)

4. General requirements

4.1. The **solar** domestic hot water cylinder **MUST** be installed by a competent person in accordance with section **G3** of the current **Building Regulations** and any other regulations in force at the time of install.

4.2. It is essential to read and understand these instructions, unpack and familiarise yourself with the equipment before commencing the installation. Failure to observe these installation instructions could invalidate the warranty.

4.3. Water supply – The water supply to the cylinder should be potable water direct from a public mains water supply with any water treatment equipment functioning correctly.

The unit, should be fed via a 22 mm diameter supply pipe direct from the mains water entry point to the property. It requires a supply pressure of 1.5 bar with a flow rate of at least 20 litres per minute as a minimum for it to function, but flow from the outlets will be low if several outlets are used simultaneously. Correct performance is achieved with supplies between 3bar and 12bar. The cylinder control equipment is factory set to limit the system operating pressure to 3.5 bar. The maximum supply pressure into the pressure-reducing valve is 12 bar.

4.4. Taps and fittings - All taps and fittings incorporated in the unvented system should have a rated operating pressure of 7 bar or above.

4.5. Location – The cylinder is designed to be floor standing, vertically mounted, indoors, in a frost-free environment. When choosing a suitable location for the cylinder, consideration should be given to the routing of the discharge pipe to a convenient safe and visible point and also the location of the solar system.

The cylinder may stand on any flat and level surface, provided that it is sufficiently robust to support the weight of the cylinder when full of water. (See Technical specifications for weights).

The position of the cylinder should be such that easy access is provided for servicing the controls and replacing the immersion heater should the need arise.

Pipe runs should be made as short as possible and lagged according to current building recommendations to prevent heat loss.

4.6. Storage and handling – If the cylinder is not being installed immediately, it should remain in its carton with all pipe end protective caps in place to prevent damage.

4.7. Pipework connections – All Pipework connections to the cylinder **MUST** be made in accordance with Fig 4.1 /4.1a, the secondary return being optional.

- 4.7.1 The **EXCELSTOR** SOLAR unvented cylinder must be installed by a competent person with appropriate qualifications and registration for the installation of unvented water storage heaters.
- 4.7.2 The cold water feed to the cylinder must be fed through the pressure reducing valve, take care to install this in the correct direction (see arrow on side of valve) and then the pressure relief valve, with the expansion vessel Tee'd off between the pressure relief valve and the cylinder.
- 4.7.3 For the single coil cylinder the immersion must be connected and suitably controlled to bring the temperature of water to 60°C following heating by the solar source.

4.8 Hard Water Areas – In hard water areas it is advisable to use a water softening device to minimise scale build-up. Periodically the immersion should be removed and scale scraped away from the bottom of the cylinder to avoid scale surrounding the immersion and causing failure.

5. Primary circuit installation

5.1. Firebird Solar cylinders are suitable for connecting to a solar collector system and where a twin coil is present, to a gas or oil central heating boiler.

Solid fuel or wood burning boilers, and gravity circulation systems MUST NOT be used on the primary circuit of an unvented hot water system!

5.2. Systems design – The cylinder must be installed in accordance with the solar installation instructions for connection to the primary flow and return.

5.3 Two-port Motorised valves – The **EXCELSTOR** range of cylinders must only be connected to solar installations containing two non return valves (one in the flow to the collector and one in the return), that will prevent thermal siphoning of the heat transfer fluid when the pump is switched off. Where two non-return valves are not present in the solar system a second twin port valve must be installed into the flow of the solar coil and wired to the lower twin-port valve.

5.3.1 The **EXCELSTOR** cylinder comes with one two-port motorised valve, which should be connected in the flow to the auxiliary coil and wired to the upper twin thermostat of the cylinder.

6. Secondary circuit installation.

6.1. Connections. Secondary circuit connections **MUST** be made to the cylinder in accordance with Fig 4.1/4.2. A drain cock (not supplied) should be fitted in the cold water inlet to facilitate draining of the cylinder.

6.2. Cold water supply – Where possible, for best results, the cylinder should be fed by an uninterrupted 22mm supply pipe into the pressure reducing valve (PR valve) with a supply pressure of between 3 and 12 bar maximum. The cylinder should not be used on any system with a supply pressure below 1.5 bar and a flow rate of less than 20 litres per minute.

6.3. Temperature and pressure relief valve – The temperature and pressure relief valve (T&P valve) is supplied factory fitted to the cylinder. The TPV must not be removed from the cylinder or tampered with in any way. The valve is pre calibrated to lift at 7 bar or 90 degrees centigrade and any attempt to adjust it will invalidate the warranty and could affect the safety performance of the unit.

6.4. Inlet Group – The inlet valve group (consisting of non-return valve; line strainer; pressure reducing valve; and expansion relief valve) should be installed in the cold water supply to the cylinder with the arrow pointing in the direction of water flow in accordance with Fig 4.1/4.2. This can be

connected to a supply pressure of between 1.5 and 12 bar. No other valve should be fitted between this group and the cylinder.

6.5. Expansion vessel – A suitable expansion vessel with a pre-charge pressure of 3 bar is supplied for fitting to all cylinders. The expansion vessel **MUST** be fitted between the expansion relief valve and the cylinder. The expansion vessel **MUST** be positioned with the entry point at the bottom. The expansion vessel should be installed using a standard t-connector ensuring no other valve is between this and the cylinder. Adjust the pressure to 3.5bar

IMPORTANT: Regular checks must be carried out to ensure that the expansion vessel is correctly pressurised to 3.5 bar at all times.

6.7. Secondary circulation – If the solar cylinder installation requires a secondary circulation circuit, a 15mm return leg, which incorporates a check valve should be connected to the secondary return of the cylinder See fig 4.1/4.2.

IMPORTANT: If a secondary circulation circuit is installed then a larger expansion vessel may be required to handle the increase in water volume. Calculate the additional water volume and contact the Firebird customer services department regarding suitable vessel sizes.

6.9. Tundish – The tundish must not be positioned above or in close proximity of any electrical current carrying devices or wiring. The installation should conform with the requirements of item 6 above. The Tundish connected to the T&P valve must be situated within 500mm of the T&P valve outlet.

6.10 Balanced Take-off – The inlet group contains a 22mm cold water take off that is of the same pressure as that of the hot water. This outlet may connected to a mixer shower for improved mixing performance. Do not connect this balanced cold water outlet to standard cold water taps as this reduces the water supply to the cylinder creating poor hot water flows. A check valve should be inserted into all Balanced take off supply lines.

6.11 Safety valves – the pressure relief valve and temperature relief valve of the unvented system are safety devices and should only be connected as described in section 7 and not be used for any other purpose.

7. Discharge arrangement.

The T&P valve may be discharged vertically into the tundish , with the pressure reducing valve T'd in from the side (see Fig 7.1 below). The Tundish must be installed in a position so that it is clearly visible by the user. In addition, the discharge pipe from the Tundish should terminate in a safe place where there is no risk to persons in the vicinity of the discharge, be of metal and:

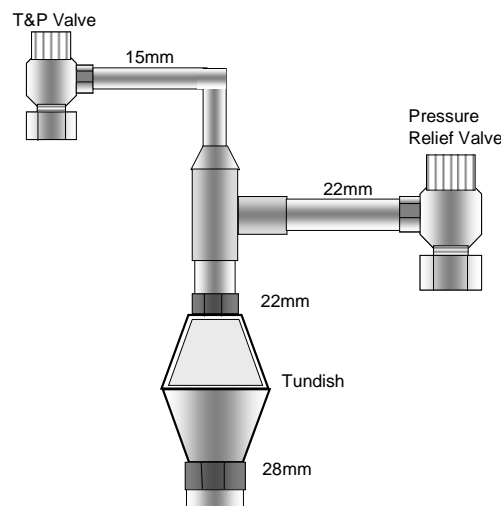

Fig 7.1

(a) Be at least one pipe size larger than the normal outlet size of the safety device unless its total equivalent hydraulic resistance exceeds that of a straight pipe 9 m long, i.e. discharge pipes between 9 m and 18 m equivalent resistance length should be at least two sizes larger than the normal outlet size of the safety device, between 18 m and 27 m at least three sizes larger and so on. Bends must be taken into account in calculating the flow resistance. Refer to the diagram, tables and worked example detailed in Fig 7.3.

(b) Have a vertical section of pipe at least 300 mm long below the Tundish before any elbows or bends in the Pipework.

(c) Be installed with a continuous fall

(d) Have discharges visible at both Tundish and the final point of discharge, but where this is not possible or practically difficult, there should be clear visibility at one or other of these locations. Examples of acceptable discharge arrangements are:

- Ideally below a fixed grating and above the water seal in a trapped gully
- Downward discharge at low level, i.e. up to 100 mm above external surfaces such as car parks, hard standings, grassed areas, etc. providing that where children play or otherwise come into contact with discharges, a wire cage or similar guard is positioned to prevent contact whilst maintaining visibility.
- Discharge at high level, e.g. into a metal hopper and metal down pipe with the end of the discharge pipe clearly visible (Tundish visible or not) or onto a roof capable of withstanding high temperature discharges of water and being 3 m from any plastic guttering system that would collect such discharges.
- Where a single pipe serves a number of discharges such as in blocks of flats, the number served should be limited to not more than six systems so that any installation discharging can be traced reasonably easily. The single common discharge pipe should be at least one pipe size larger than the largest individual discharge pipe to be connected. If unvented hot water stored systems are installed where discharges from safety devices may not be apparent i.e. in dwellings occupied by blind, or disabled people, consideration should be given to the installation of an electrically operated device to warn when discharge takes place.

Warning Notice – The discharge will consist of scalding water and steam. Asphalt, roofing felt and non-metallic rainwater goods may be damaged by such discharges.

Typical discharge pipe arrangement.

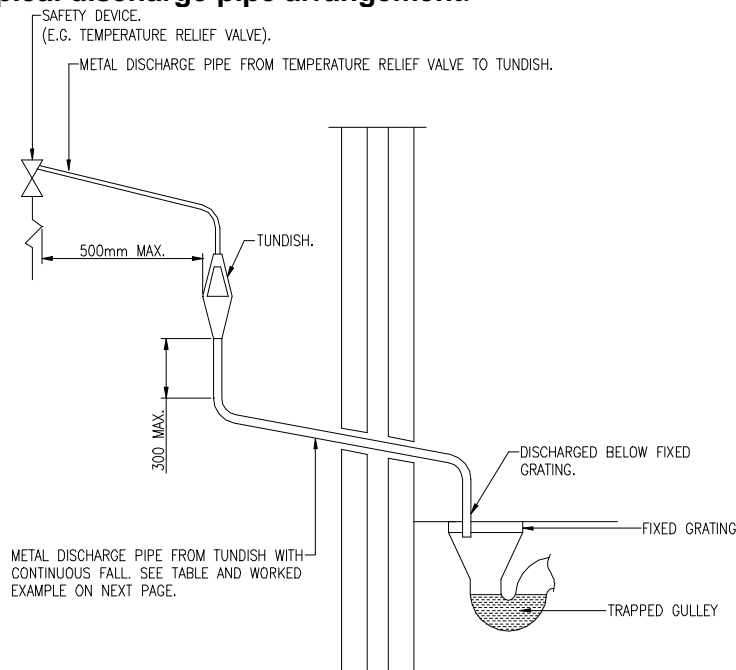

Fig 7.2

Valve outlet size Diameter	Min. size of Discharge pipe D1	Min. size of Discharge pipe D2 from Tundish	Max. length of Straight pipe	Resistance created by each elbow Or bend
1/2"	15mm	22mm	Up to 9m	0.8m
		28mm	Up to 18m	1.0m
		35mm	Up to 27m	1.4m
3/4"	22mm	28mm	Up to 9m	-
		35mm	Up to 18m	-
		42mm	Up to 27m	1.7m
1"	28mm	35mm	Up to 9m	1.4m
		42mm	Up to 18m	1.7m
		54mm	Up to 27m	2.3m

Fig 7.3

Worked example

The example below is for a 1/2" diameter temperature relief valve with a discharge pipe (D2) having 4 elbows and a length of 7 m from the tundish to the point of discharge.

From the table above the maximum resistance allowed for a straight length of 22mm copper discharge pipe (D2) from a 1/2" diameter temperature relief valve is: 9.0 m.

Subtract the resistance for 4 No 22mm elbows at 0.8 m each = 3.2 m.

Therefore, the maximum permitted length equates to: 5.8 m.

5.8 m is less than the actual length of 7 m, therefore, calculate the next largest size.

Maximum resistance allowed for a straight length of 28mm pipe (D2) from a 1/2" diameter temperature relief valve equates to: 18 m.

Subtract the resistance for 4 No 28mm elbows at 1.0 each = 4 m.

Therefore the maximum permitted length equates to 14 m.

As the actual length is 7 m, a 28mm diameter copper pipe will be satisfactory.

8. Electrical installation

WARNING: THIS EQUIPMENT MUST BE EARTHED.

All electrical wiring must be carried out by a competent person and in accordance with the **current I.E.E. Wiring Regulations**.

The control equipment supplied will ensure that the cylinder functions safely. It is intended that these controls operate in conjunction with other control packages as described in the Solar system installation guide which incorporates a programmable time clock etc.

8.1. The immersion heater - A 3kW 230v 50Hz immersion heater is supplied with the cylinder. It should be wired in accordance with the instructions given in Fig 8.1. The cable **MUST** be routed through the strain relief bush. We recommend that the control thermostat is set at 60°C, the high limit trip is factory set at 85°C.

8.2 Immersion heater wiring instructions

The immersion should be installed and wired in accordance with the instructions supplied with the immersion itself, the following should also be observed:

- Ensure the mains voltage corresponds to the voltage rating of the immersion heater as shown on the rating label on the terminal cover.

- b) Insert the immersion into the immersion heater boss at the bottom of the cylinder. Tighten using an appropriate sized immersion spanner, or as required by the immersion instructions.
- c) Wire the immersion heater through a double pole isolator switch or controller, having contact separation of at least 3 mm, using 1.5mm sq. flexible cable which must be fully earthed. The live to the immersion should be wired through its thermostat and cut-out as shown in figure 8.1, the Neutral to the Neutral terminal.
- d) In the event of the manual reset cut-out operating, isolate the immersion heater from the mains supply, investigate and identify the cause of the operation of this cut-out, rectify the fault before manually resetting the cut-out via the reset button on the cut-out. Finally switch the mains electricity supply back on.
- e) Do not install an immersion heater without a thermal cut-out.

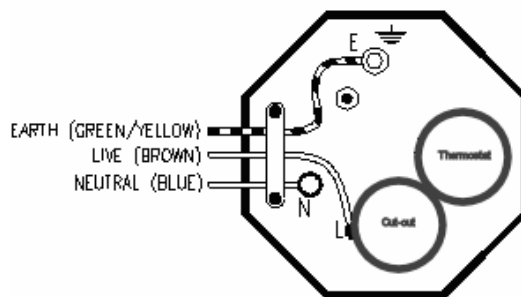

WARNING: THIS APPLIANCE MUST BE EARTHED.

8.2.1 The two port valve should be wired to the twin thermostat as per Figure 8.2 below:

8.2.1.1 Connect the Live supply to the thermal-cut-out and connect the brown wire of the two-port valve to terminal 2 on the thermostat. Earth and Neutral supplies can be connected directly to the valve.

8.2.1.2 The orange wire of the two-port valves should be connected one to the central heating boiler.

8.2.1.3 The cylinder thermostat should be set to 60°C

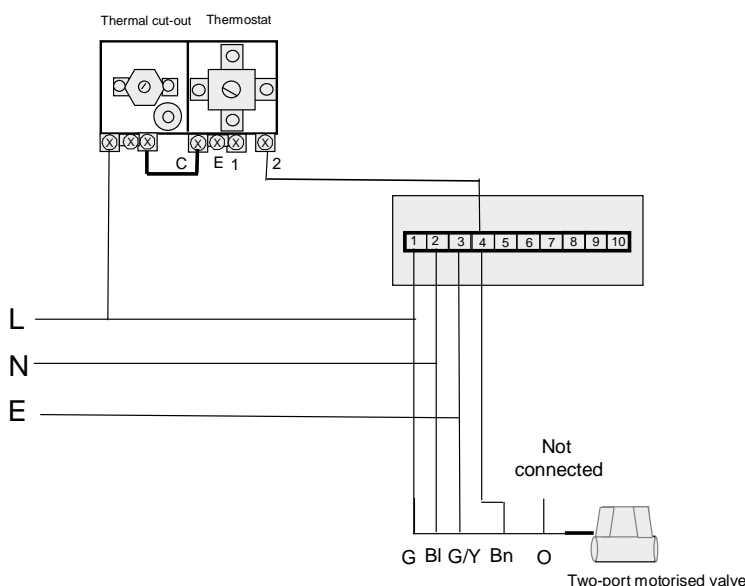

Fig 8.2

9. Filling and commissioning

- 9.1. Check that the expansion vessel charge pressure is 3.5 bar.
- 9.2. Check that all connections are tight and correctly configured.
- 9.3. Open the main stopcock and fill the secondary system. Open successive hot taps. Leave each tap open for a few minutes to allow all air and debris from the system to exit. Close all taps.
- 9.4 Turn off the mains water supply to the cylinder and drain the system through the drain cock.
- 9.5 Refill the cylinder with hot taps open and close when water flows freely.
- 9.6 Manually lift (by rotating the knob) both the expansion relief and the temperature and pressure relief valve for a short period to remove trapped air from behind the valve seating and to prove the correct function of the discharge arrangement.
- 9.7. Check all joints for leaks and rectify as necessary.
- 9.8. Check that the control thermostat on the immersion is set 60°C and the high limit thermostat is correctly connected to all appropriate safety controls.
- 9.9. Fill the primary side as per the solar installation instructions, (note:- it will be necessary to Check for leaks and rectify as necessary). Commission the solar system and heating system in accordance with manufacturers instructions
- 9.10 Check that while the cylinder is heating up, no water exits from either the expansion relief or the temperature and pressure relief valve.
- 9.11 When the solar system reaches its maximum operating temperature the pump should stop operating. The immersion should then come on to heat the water to the desired temperature of 60°C in accordance with any timing controls on the heat pump system. The immersion may be on a timer and not come in until set times of the day or night, if so the immersion should be switched on manually. Check that the immersion switches off when the cylinder reaches the desired temperature.

10 Servicing and maintenance.

- 10.1. Servicing and maintenance must only be carried out by a competent unvented hot water installer or by Firebird authorised personnel.
- 10.2. Before any work whatsoever is carried out on the installation, it **MUST** first be isolated from the mains electricity supply.
- 10.3. **WARNING:** both the primary and secondary systems will contain very hot water that will scald, therefore care should be taken when opening any joints, seals or valves.
- 10.4. Only use spare parts authorised by Firebird. The use of other parts will invalidate the warranty.
- 10.5. Having isolated the electricity supply, drain the cylinder. When draining the cylinder, always switch off the solar system pump and the immersion heater first. Turn off the water supply at the stopcock (see Fig 4.1 / 4.2). Connect a hosepipe to the drain cock (see Fig 5) and route it to a convenient place. Open the drain cock and all hot taps that are served by the cylinder. The cylinder may take several minutes to empty completely.

10.6. Remove the cartridge from the pressure reducing valve (PRV). Check the strainer and if necessary remove any debris from in front of it. Replace the cartridge.

10.7. Check the charge pressure in the expansion vessel and top up as necessary. The charge pressure should be **3.5 bar**.

10.8. Periodically the immersion heater should be removed, and the cylinder flushed out to remove any debris, sand or limescale particles that may have collected in the bottom.

10.9. In hard water areas it may be necessary to remove and de-scale the immersion heater element. Replace the gasket each time it is removed. If large amounts of scale is present it may be advisable to fit a water softening device.

10.10. To refill the cylinder, close the drain cock, disconnect the hose, refit the immersion heater with new gasket and close all hot water taps before reopening the stopcock. Allow the cylinder time to fill whilst checking for any leaks. Release any air from the system by opening each hot water tap individually, starting with the one furthest from the cylinder.

10.11. Manually lift the expansion relief and temperature and pressure relief valve one at a time, every 12 months (more frequently in hard water areas) to prevent debris from building up behind the valve seat. Whilst carrying out this operation, check that the discharge to waste is unobstructed. Check that each valve seals correctly when released. As the valves are pre-calibrated, they require no further maintenance.

10.12. Finally switch on the mains electricity supply to the immersion heater and the solar system. Turn the system on to heat the water. As the system heats up, check again for any leaks and rectify as necessary.

11 Fault finding

Notice: Disconnect electrical supply before removing any electrical equipment cover.

Fault	Possible cause	Remedy
No hot water	<ol style="list-style-type: none"> 1. Mains supply off 2. Strainer blocked 3. Pressure reducing valve (PRV) fitted the wrong way 	<ol style="list-style-type: none"> 1. Open stopcock 2. Turn water supply off, remove strainer and clean. (see 10.6) 3. Re-fit with arrow pointing in direction of flow
Water from hot taps is cold	<ol style="list-style-type: none"> 1. Programmer set to heating only or not switched on for hot water 2. Central heating boiler malfunction 3. High limit thermostat has tripped 4. Pump malfunction 	<ol style="list-style-type: none"> 1. Set programmer to call 2. Check boiler operation if faulty consult your boiler manufacturers instructions 3. Check and re-set 4. Check wiring and/or plumbing connections to pump
Intermittent water discharge through tundish on warm-up	<ol style="list-style-type: none"> 1. Expansion vessel has lost its charge pressure 	<ol style="list-style-type: none"> 1. Turn off stopcock open a hot water tap check vessel charge pressure and recharge to 3 bar
Continuous water discharge	<ol style="list-style-type: none"> 1. Pressure reducing valve (PRV) not working 2. Expansion relief valve not seating correctly 3. Temperature and pressure relief valve not seating correctly 	<ol style="list-style-type: none"> 1. Check pressure from PRV if greater than 3.5 bar replace cartridge 2. Manually lift the valve once or twice to clear any debris from the seat otherwise replace valve 3. Manually lift the valve once or twice to clear any debris from the seat otherwise replace valve

12 Users instructions

12.1 Your **EXCELSTOR SOLAR** unvented hot water cylinder has been designed to give many years of trouble free service and is made from hygienic high-grade stainless steel. It includes a 2-3 kW electric immersion heater, which heats the water to 60°C once pre-heating from the solar system is completed.

12.2. The flow temperature of the hot water can be set to your requirements on the immersion heater ideally 60°C. Higher temperatures can cause tripping of the high limit thermostat and introduces more energy loss from the cylinder.

12.3. When a hot tap is turned on there may be a short surge of water, this is quite normal with unvented systems and does not mean there is a fault.

12.4. When you first fill a basin the water may sometimes appear milky. This is due to very tiny air bubbles in the water, which will clear very quickly.

12.5. WARNING: If cold/warm water exits from the temperature and pressure relief valve (TPV) or from the expansion relief valve (EV) call your installer or the Firebird customer service centre. If very hot water exits from either valve switch off the heat source immediately and isolate the electricity supply to the cylinder and separate heat source.

12.6 The solar system is configured to heat the water to its maximum economic temperature, which may vary with outside temperature and weather conditions. The immersion may be programmed to operate during fixed periods of the day or night. If the hot water runs cool it may be necessary to manually switch on the immersion to heat the water – please see heat pump instructions.

13 Warranty

13.1. Firebird Limited guarantee all electrical and mechanical controls supplied with the cylinder for a period of 2 years from the date of purchase provided that they have been installed for their intended use by a competent person and have not been modified in any way.

13.2. In addition Firebird Limited also guarantees the hot water cylinder for a period of 5 years from the date of purchase against faulty material or manufacture provided that:

- (a) It has been installed by a competent person in accordance with this installation manual and all current regulations and codes of practice at the time of installation.
- (b) It has been used solely for the purpose of heating potable water that complies with current (at the time of installation) EU standards and is not fed with water from a private source.
- (c) It has not been modified in any way.
- (d) It has not been subjected to excessive pressure or electrolytic action from dissimilar materials, or attack from any salt deposits.
- (e) It has been installed indoors in a frost-free environment.
- (f) The warranty card is completed and returned to Firebird Limited within 90 days of installation.

This warranty is not transferable. This warranty does not include claims due to frost or lime scale damage. Proof of purchase will be required against any claim. This guarantee does not affect your statutory rights.

14 Spare parts

- Expansion vessel 24litre
 18litre
 12litre
- Expansion vessel bracket
- Inlet Valve Group
- T/P valve 7bar 90°C 230mm
- 15mm to 22mm Tundish
- 3kW Immersion heater
- 22mm Pressure reducing valve
- 22mm pressure relief valve
- 28mm 2-port motorised valve
- Twin Cylinder Thermostat

For assistance please contact the Firebird Customer Services Department:

